



www.gatormodelers.org



Remembering D-Day

From John McManus' book "*The Dead and Those Who Are About To Die:*"

"A famous photograph, taken from a Coast Guard Higgins boat, of C Company, 16th Infantry Regiment, 1st Infantry Division, landing about sixty minutes after H-Hour at Easy Red Beach"

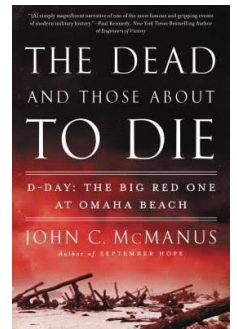

Bob Lundeen's OS2U Kingfisher – Winner of the 6th-month club contest: Best "Rescue Vehicle"



Jack Mugan's F6F Hellcat – Winner of the monthly theme contest – Sinking of the Yamato





GATOR MODELERS

GAINESVILLE, FLORIDA

Club officers

A. J. Kwan
President &
Associate
Newsletter
Editor

Dan Contento
Vice Pres

Frank Ahern
Secretary

Bruce Doyle
Historian

Paul Bennett
Photographer

Tracy Palmer
Webmaster

Bill Winter
Treasurer &
Newsletter
Editor

www.gatormodelers.org

Next meeting:

Tuesday June 18, 2019 at: 6:30 PM
Oak Hall Library
1700 SW 75th St, Gainesville FL

(See the map on page 48)



IPMS Gators make the big league as Fine Scale Modeler's Aaron Skinner wears an IPMS Gators' golf shirt during a FSM product review (see: http://finescale.com/videos/new-product-rundown/2019/05/new-product-rundown-159-video-review-rodenc133?utm_source=Yesmail&utm_medium=email&utm_campaign=News0_FSM_190522_00000)

Table of Contents

		Show and Tell	23
		Bills' Column	26
Pres Sez	3	Odds and Ends	28
Meeting minutes	5	Coming events	44
Technique Topic: Polished not Painted!	6	More Odds & Ends	22
How to clean an airbrush	8	Secretary's page	46
Fiddly Bits	11	IPMS Membership	47
Hollywood Heroes	21	Directions to meeting	48
		Wild Paint	49

Prez Sez.....

By AJ Kwan

Please come join us. We are having a ball with some very interesting presentations and modeling technique discussions.

Some Reminders

- Mugs (dishwasher safe, under \$10) might be available
- Get your shirt or t-shirt ordered.

Technique Presentation/Discussion

- Don Wilson's Presentation on Weathering, Dioramas/Vignettes was riveting... well, maybe super gluing?



- Do you know all the stuff in the picture? And how to use it?

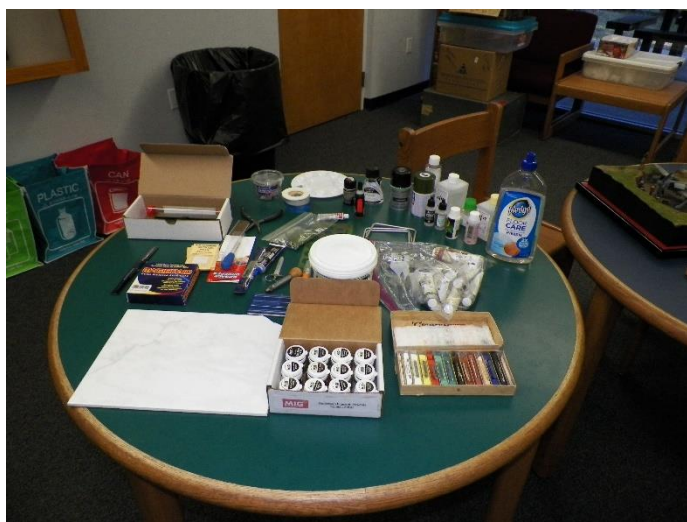

Prez Sez.....

- Didn't get the handout? You should have been here!! Come to the next meeting and we will get you one.

June Meeting

- Theme is Operation Overlord, D Day
- Technique Presentation – Brian Cormack, decals ☺

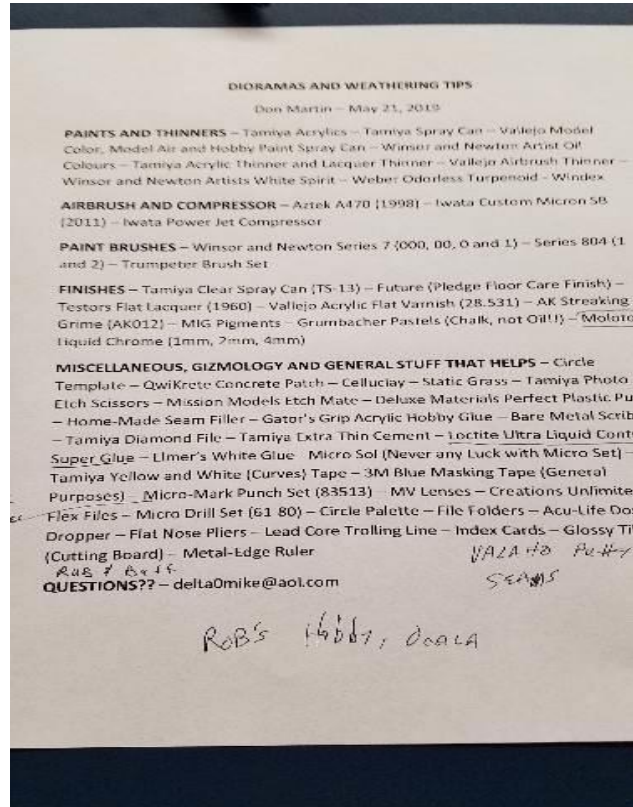

00_1982 Don Martin's Technique Presentation ☆

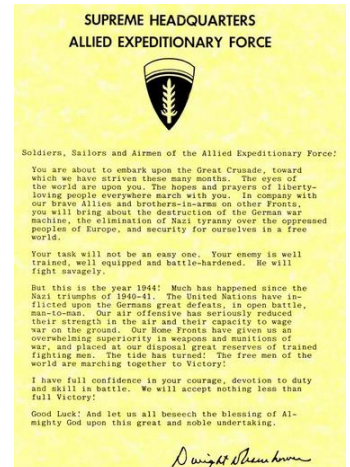

Meeting Minutes – May 21, 2019

By Frank Ahern



President AJ Kwan opened the meeting at 6:35pm welcoming 15 club members and five guests – Allen Kauffman, who joined the club, John Wegenska, Dick Rosenboom, Gen. Paul Albritton, and Amy Burns.

Ms. Burns presented the club’s re-designed website, which she had contracted with the club to produce. The new site is designed to be easier to use and update and to display better on smart phones. It is also capable of linking club members to a photo storage website where each member can have their own archive of model photos. It will still be accessed through the club’s original website – gatormodelers.org The new site is scheduled to be available as soon as club webmaster Tracy Palmer coordinates with Ms. Burns on the new features.

The President declared a break while members assembled at the model tables for Show & Tell and two model contests. The semi-annual themed contest on the theme “Rescue” was judged by the club and the winner was Bob Lundeen’s model of an OS2U Kingfisher (see cover of this issue).

The monthly historic theme was the sinking of the Yamato and the winner was a Grumman Wildcat by Jack Mugan (see cover of this issue). Lundeen picked the theme of the next model contest in November. His choice of theme is “Amphibious.”

Don Martin gave a Technique Talk on the various products and tools he uses to produce award-winning models. His talk encompassed a wide variety of paints, glues, tools and other products and generated a good interchange of questions and comments with club members.

The monthly attendance raffles were held and the winners were Chuck Lassiter, who selected a trio of items, including a team of anti-tank figures, and Ed Ingersoll who picked a Tamiya M-16 tank.



Soviet Motorcycle M-72 with 82 mm mortar (1:35; Zvezda)



1:72 Anti-teams figures (added Jan 2016- Donation from Paul Bennett)



Greek Evzones (1940-1941) (1:35; ICM)

These are 1 choice!

Finally, Frank Ahern gave a Powerpoint presentation on his research into the Berlin Airlift, which ended 70 years ago this month. General Albritton also contributed his memories of serving in Germany in the years after the airlift and the challenges of maintaining military readiness in and around Berlin during the cold war era.

The meeting ended at 8:50pm.

Technique Topic: **Polished not Painted!**

By Frank Ahern

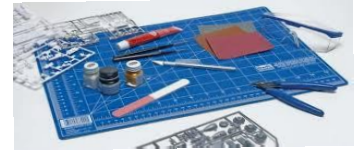

After more than a decade as a modeler I thought I'd seen about everything. Then came the meeting last January when Clarence Snyder brought in a beautiful car model with a deep, shiny, flawless finish.



I complimented him on the outstanding paint job, the kind every car modeler strives for. "It's not painted" he said, "It's polished". There's a pause here while I pick up my jaw off the floor. Immediately my mind starts racing back to all my failed efforts to get that kind of look by painting. The splattering, orange-peel, drips, runs, bad gloss coats, finger prints. You name it, I've done it. Now I learn that if the model is molded in an acceptable color you can avoid it all by polishing.

Amazing!

The next most amazing thing is that I already had all the stuff I needed to do this technique.



Tucked away in a dark corner of a garage cabinet I had a bottle of liquid rubbing compound designed to restore fogged headlight lenses. Next to it was an old can of Johnson's Wax. There's no magic to the brands, anything similar will do. I decided to experiment on a random unused piece of plastic from an old car kit (top left, next page).

It had the typical dull, dingy look of unpainted styrene plastic. I dampened a paper towel and started rubbing a few drops of the compound on the plastic in small circles. It was exactly like I remembered polishing my shoes in military school. When I removed the haze with a soft cloth the piece was transformed. (top right, next page) I applied the wax and buffed it to a sparkling finish. In less than 10 minutes I was done, and I didn't have to clean an airbrush. Can you say - easy!



The next step was to try it on a complete model. The club contest in May was my target. The theme was “Rescue”, so I searched the internet for a rescue model that I could use to try this new technique. I finally found a kit of a rescue van molded in red that became my test bed model.

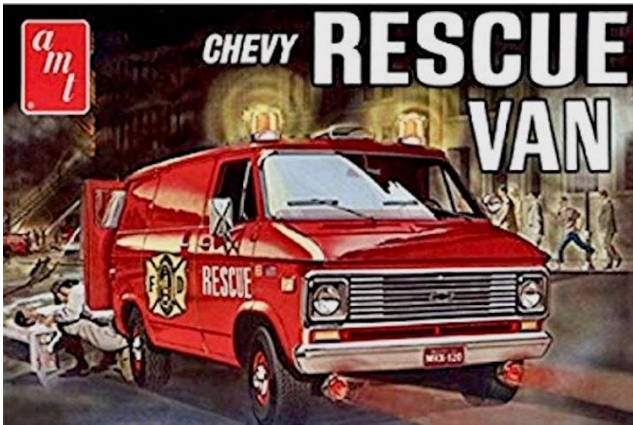

I’d like to say that it was a great kit, and everything went together well, but if I did, I’d be lying. It was a classic example of why car modeling can be so frustrating. The instructions were vague and unclear in many cases. Parts were poorly molded and didn’t fit well. I never could figure out how the engine was supposed to fit into the completed model. The good news is that I didn’t care, because the body was a perfect example of what polishing can do. (See above right) The deep, glossy, flawless finish is something I have never accomplished on a model before, so I can’t wait to find a good car model that I can use to showcase this technique.

Like all my technique articles, this one comes with disclaimers. This technique doesn’t work well on airplanes because you can’t hide seams. It is also difficult to remove the mold seams from cars so completely that you preserve the smooth pristine finish, but it’s worth the effort. Having a complete set of wet/dry polishing cloths is very helpful. The other challenge is finding a kit you like that’s molded in a color that is acceptable. My search for my next polished car is already underway.

How to clean an airbrush.

Please read this in reverse order

As an FYI, I also use lacquer thinner when cleaning my brush. I run a couple of small passes. Each pass is a couple of pipettes of thinner in the bottle. Mine uses a bottle and siphon beneath the airbrush. I then also use a paper towel between each pass to clean the siphon tube. As to spray cans, to each their own. Personally I prefer an airbrush for the precise control.

Periodic disassembly and through cleaning of the airbrush is essential. Also, for those of us who use the bottle type air brush, make sure the air hole in the lid is kept clear. –

Paul

To Andy's comments... Exactly. That is pretty much the procedure I use, given the difference in airbrush type. A quart tin of lacquer thinner is not expensive and it will clean just about anything, including acrylics.

And some side notes, so folks won't wind up crying, screaming, and tearing their hair out. I made a discovery about Testor's clear coat acrylics and Microscale Microset and Microsol. Don't!! If they are not completely dry and come in contact you will get a messy white goo and you might as well throw the paint brush out because you aren't gonna be able to clean it. I shudder to think of the inadvertent disaster if the mix occurs in an airbrush. Lacquer thinner wouldn't even move it on brushes.

And like Andy, my preferences run to lacquers and enamels. - **Paul**

A few drops of lacquer thinner or windex (using acrylics, but even then the lacquer thinner will work most of the time) dropped into the body cavity and nozzle should work most paint free within a few minutes...then you can get your needle out.

For cleaning I do pretty much the same as Tony...

After your session, spray clean thinner WITH needle in body (as though you were painting)

2- remove needle, wipe down, set aside

3- spray clean thinner through airbrush body WITHOUT needle (you have to tip the brush down and let gravity feed the thinner)

4- insert needle, spray AIR ONLY through to remove any residue thinner

5- now unscrew the needle lock nut, and back the needle into the brush about 1/4" or so so that it is no longer pushed completely in. OR remove needle completely and store outside of body.

I also wipe out the nozzle and cap with a qtip and thinner.

How to clean an airbrush. . . . *(continued)*

I tend to only do complete breakdown about once a year, and use pipe cleaners and such. I also check the rubber seals (if any).

The key is to get all residue thinner out of the body. I tend to use enamels/lacquers, so box store brand (Kleen Strip?) lacquer thinner for clean up (regardless of brand of paint used). For Acrylics, ammonia based products (windex) works great. Between the ammonia and lacquer thinner you can clean just about anything without using your expensive "brand" name stuff. - [Andy](#)

After each painting I clean the complete brush including removing the needle from the handle. A little extra work but it keeps everything clean..

Also; after I'm finished spraying I put thinner of the paint I'm using in the paint cup and pass it through the brush several times to remove the paint from the cup and brush, than I break down the brush for detail cleaning My brush is a Harder& Steenbeck. - [Tony](#)

I recommend using one of those small dental brushes to clean your airbrush in very tight places. I use one of the tiny brushes to clean inside the needle of my Badger 200nh and my Iwatas.

I start all my cleaning with a larger version and then move to the smaller ones. - [Ed](#)

I'm kind of new with airbrushing but had the same thing happen to me a short time ago. I clean my airbrush after every use, but as time passed it was getting harder to remove the needle from the airbrush, until I got to the point that it wouldn't come out at all. I thought the needle was stuck at the nozzle, turned out it was stuck in the needle chuck. I removed the set screw, dropped in a very small amount of airbrush thinner, waited a few minutes, and the needle finally came out. I then took the airbrush completely apart, except for the air valve, gave it a good cleaning, and haven't had any issues since. Hope this helps.- [Doug](#)

What type of air brush? I have a Badger 200NH. With that, there are two knurled knobs on the back. One is a locking knob to set max depth, the other is an adjustment knob to set the needle depth. It is possible to unscrew the adjustable needle all the way out, but if you do, it holds the spray button in. Not really a problem to put back, unless it makes the great escape into the depths. Also on the 200, the front consists of two fittings and an inner part that screws on. Hope this helps. Again, note, this is the Badger 200NH. Your airbrush mileage may vary.- [Paul](#)

Anyone have any suggestions on getting a stuck needle out of the airbrush body?

[From a club member.](#)

How to clean an airbrush. (last of 3 pages)

Please read this in reverse

What type of air brush? I have a Badger 200NH. With that, there are two knurled knobs on the back. One is a locking knob to set max depth, the other is an adjustment knob to set the needle depth. It is possible to unscrew the adjustable needle all the way out, but if you do, it holds the spray button in. Not really a problem to put back, unless it makes the great escape into the depths. Also on the 200, the front consists of two fittings and an inner part that screws on. Hope this helps. Again, note, this is the Badger 200NH. Your airbrush mileage may vary. - Paul

I don't mean to come off as being flippant, but in using spray can paint I never have this problem (but I don't ever remember having it when i used an air brush "back in the day"). I think what most of you wrote is correct- field strip your air-brush after EVERY use. And one more thought: Errol, are you using enamel paint? I used acrylic paint exclusively when I air-brushed, and so with a good cleaning with both water (initially), and alcohol as final stage- with a pipe cleaner to clean/clear the nozzle, I never had a needle get stuck. Thinking it over as I write this, I think the source of your problem is the use of enamel- not water-based- paint. Bruce

And let me add one comment.

Safety! Paints, including acrylics (read the labels and the MSDS), and thinners, can be nasty stuff. Setting aside true waterbase, (which I have very little experience with). Always read the labels. You would be surprised about Acrylics.- Paul

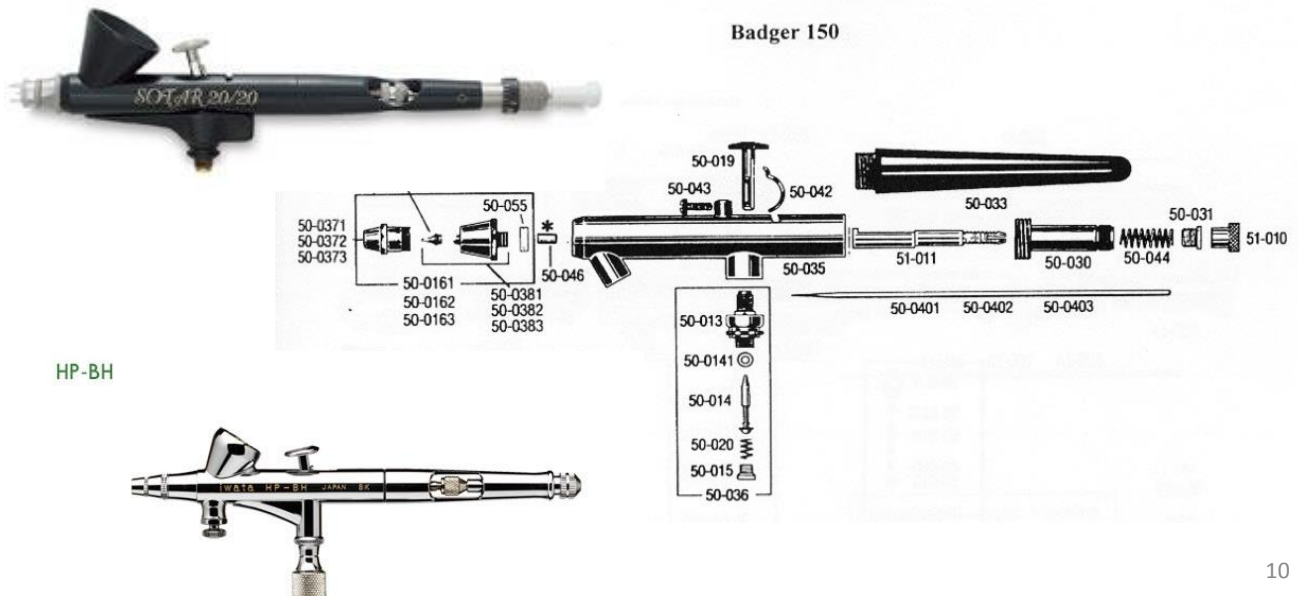

FIDDLY BITS: D-DAY, THE 6th OF JUNE, 1944

by **Bruce Doyle**
Club Historian

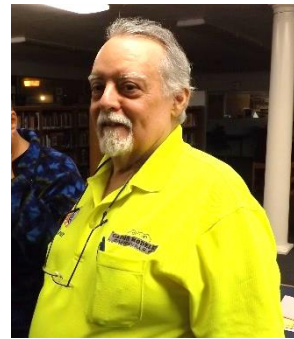

This month's theme is D-Day, and for an obvious reason - its the 75th Anniversary of the Invasion of France on June 6, 1944. You guys (and gals) are all familiar with the historical narrative of Overlord; you've read the books, seen the movies, watched the documentaries. Taking all that into account I'd like to do something different. I've gone through the first 200 pages dealing with D-Day of Rick Atkinson's final volume of his Pulitzer Prize winning 'Liberation Trilogy' - THE GUNS AT LAST LIGHT - and pulled some nuggets of information concerning D-Day: some statistics, some terms, observations, reckonings; some are mundane, some fantastical, others mind-blowing. Hopefully all are interesting and maybe even educational.



SHAEF

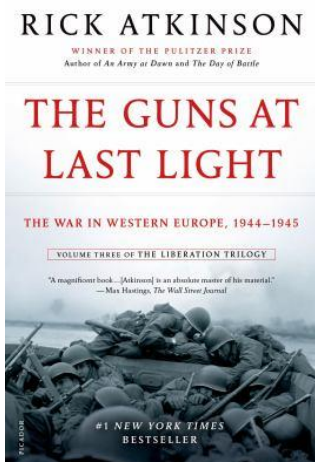

There is an old saying among military historians and military professionals: strategy is for amateurs, logistics for professionals (I am sure Mike Martinez is nodding his head now in agreement.) I hope that when you've finished reading this you'll have a greater appreciation of the herculean logistical task of planning, organizing and executing OVERLORD in general, and greater respect - if that's possible - for the leadership skills of SHAEF's (Supreme Headquarters, Allied Expeditionary Force) Commander, Gen. Dwight D. Eisenhower in particular. His was a monumental, six month, 7 days a week, 25-hours-a-day mission.

To help relieve the stress of the job Ike chain-smoked four packs-a-day of Camels (he switched to Chesterfields in July). He suffered from

FIDDLY BITS: D-DAY, THE 6th OF JUNE, 1944

hypertension (high blood pressure.) His BP was 170 over 110, and he had a constant ringing in his ears. (Churchill coped by consuming alcohol in copious amounts: Bourbon in the morning, cognac at noon, and champagne all night until the wee hours of the morning.) However, Eisenhower's blood pressure readings pale when compared to his Commander-in-Chief-President Roosevelt whose daily BP averaged 220 over 170 mmHg. On the day FDR died it was 300 over 190. To say winning a War was a stressful job is a colossal understatement if ever there was one. Strong men died young, and not just from bombs and bullets.



Now on to some serious (Fiddly) "Bits-of-Tid", nuggets panned from Atkinson's magnificent work:

* In 1944 the Germans suffered 3.5 million casualties: killed-in-action (KIA); wounded-in-action (WIA); and missing-in-action (MIA); Soviet casualties were four times as many.

* In 1944 the Germans had 193 Divisions on the Eastern Front; 28 in Italy; 18 in Norway; and 59 in France. SUMMARY: Two thirds of all German Divisions were in Russia. CONCLUSION: The Soviet Union defeated Nazi Germany, albeit with some timely help from their British and American Allies.

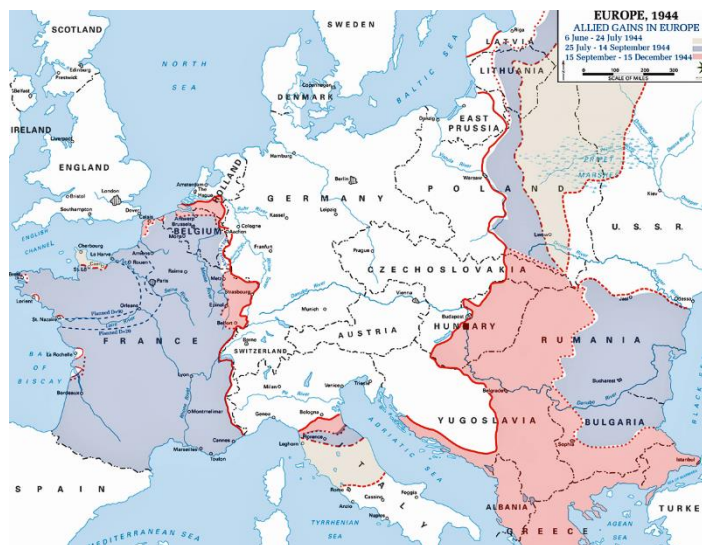

FIDDLY BITS: D-DAY, THE 6th OF JUNE, 1944

- * Not found in Atkinson, but I remember hearing 80% of all German casualties occurred on the Eastern Front.
- * ACRONYM USED AT SHAEF: "PINWE"- "Problems of the Invasion of Northwest Europe"
- * 160,000 tons of chemical weapons were stockpiled in England to use in retaliation if Hitler ordered poison gas to be used on the Invasion force.
- * TERM: "Snowdrops" - what American MP's were called because of their white helmets.
- * (Some guy named) LOWE'S PRE-INVASION ESTIMATE OF ALLIED CASUALTIES: 12% of the entire assault force would be KIA, WIA, or MIA; the 1st Division- "The Big Red One" - on Omaha Beach would suffer 25% casualties; 30% to 50% of the ships in the invasion fleet would be sunk; combat drownings were estimated to be 16,726 (stats like these kept Ike up at night.)
- Eisenhower was offered \$150,000 by a Hollywood agent for his life's story (Mamie and Ike's mother were offered \$7500 apiece for theirs'.)



- * There were 1.5 million G.I.'s pre D-Day in England, arriving 15,000 at a time on the two Queens: HMS Queen Mary and HMS Queen Elizabeth.
- * Average G.I. was 26 years old; however, due to the loss of infantrymen 50% were teenagers by D-Day; 1 in 3 only finished grade school; only 1 in 4 graduated from high school; only 1 in 10 had a semester in college.

FIDDLY BITS: D-DAY, THE 6th OF JUNE, 1944

* PAY: \$50 / month for a private; \$96 / month for a Staff Sargent; and if you had the Medal-of-Honor you got \$2 more per month.

- AVERAGE G.I.: was 5' 8", 144 lbs.; could be drafted if his 20 / 400 vision could be corrected to 20 / 40; Army therefore made 2.3 million pairs of glasses.

- Due to the need for infantrymen by 1944 it was okay if you only had one eye; if you were deaf in one ear; were missing a thumb or a finger (just not your trigger finger.)

- DENTAL CARE: One third of all civilian dentists were drafted into the military; they provided the G.I.'s with 15 million extractions; 68 million fillings; and 2.5 million sets of dentures.



- In England the G.I.'s were housed in 1,200 camps, 133 airfields, 400,000 pre-fab huts; 279,000 tents, 112,000 borrowed British buildings; 20 million square feet of storage space, all housing 23 million tons of war material and the 1.5 million soldiers. England was rightfully nicknamed by the G.I.'s as "Spamland." Some wags commented that they better hurry up with the invasion before England sank!



* The British produced to provision the American Army with: 240 million pounds of potatoes; 1,000 cake pans; 2.4 million tent pegs; 15 million condoms; 260,000 grave markers; 80 million packets of cookies; and last but certainly not least- 54 million gallons of beer.

- For OVERLORD there were gathered for shipment to France: 301,000 vehicles; 1,800 locomotives; 20,000 railcars; 2,700 artillery pieces; 300,000 telephone polls; 7 million tons of gas, oil, and lubricants all of which had to be shipped across the Atlantic Ocean, off-loaded, unpacked, sorted and labeled, re-loaded onboard ships using combat-loading priorities for off-loading in France. Could this be done today? I have my doubts.



FIDDLY BITS: D-DAY, THE 6th OF JUNE, 1944

* Estimate for the AVERAGE DAILY CONSUMPTION of gas, ammo, food, etc per soldier which would have to come across the beach: 41.298 lbs. per man per day.

* SHIPPED OUT were: 60 million K-Rations (yum); 3,000 tons of maps; 210 million maps distributed in England pre-Invasion; 28,000 hydrographic charts of French beaches; and 1 million aerial photos of Normandy.

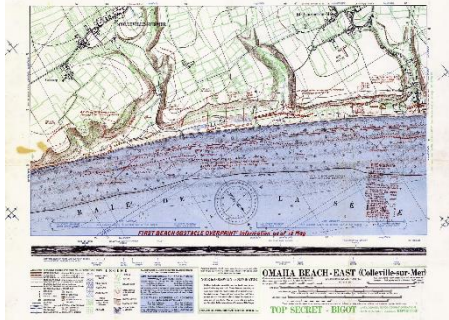

• The U.S. 1st Army's (Omar Bradley) Battle Plan for D-Day was longer than the novel "Gone With the Wind".

* TERMS: The Purple Heart - with some G.I. 'black humor'- was known as "The German Marksmanship Medal".

* To Take Care of D-Day Casualties: Shipped out were 10,000 canvas body bags; 100,000 metal cemetery crosses; four Hospital Ships were deployed to Normandy; 8,000 doctors, both in France and England, were to treat the wounded, both Allied and German, with: 600,000 doses of penicillin; 50 tons of sulfa drugs; 800,000 pints of plasma, segregated by race (by black and white, this was, after all, 1940's America ☹ .)

* D-DAY STRIPES: 11,000 Allied aircraft (planes and gliders) were painted with 100,000 gallons of whitewash using 20,000 brushes.

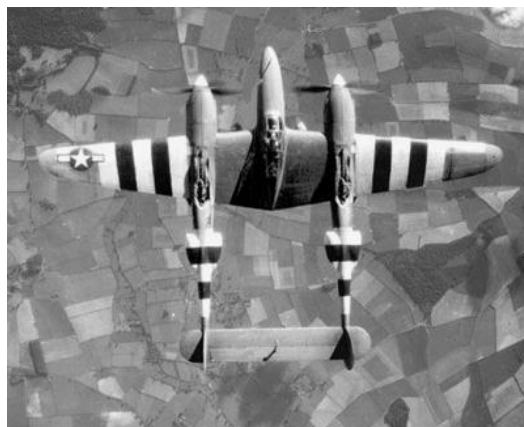

FIDDLY BITS: D-DAY, THE 6th OF JUNE, 1944

- **WATERPROOFING:** It took a tank's 5-man crew a week to waterproof their Shermans with a gooey concoction of grease, lime, and asbestos (sue for mesothelioma?)



* **AVERAGE COMBAT LOAD** per man landing on the beach was 68.4 pounds (remember their average weight was 144 lbs.). This tragically caused a lot of men to drown before reaching the beach.

* **THE INVASION ARMADA** had: 7,000 ships, including landing craft and barges; they were crewed by 200,000 seaman and merchant marines; gathered in 59 separate convoys; carrying 130,000 soldiers, 2000 tanks, 12,000 vehicles all through ten channels swept by minesweepers on the night of June 5th right under the noses of the Germans who never saw them.

- On board the ships were 40 War Correspondents, who were considered "dead weight" by some disgruntled generals.

- **TERM:** "The \$10,000 Jump" was used by paratroopers of the 82nd and 101st Airborne Divisions referring To their \$10,000 G.I. Life Insurance Policy.

- They were carried in 816 transports plus 100 gliders, and by dawn of June 6th there were 13,000 paratroopers in France.



- * The Combined USAAF and RAF flew 15,000 sorties on the 6th.

- * **BOMBS AWAY:** The entire force of 1,635 America bombers, including 1,350 B-17s and B-24s, flew tactical bombing missions to support the Invasion; 9th A.F. B-26s dropped 4,414 tons of bombs on the Contentin Peninsula; USAAF and RAF After Action Reports showed only 2% of all the bombs dropped hit the assault area, none hit the shoreline (Gen. Bradley did not want bomb craters impeding the exit from the beaches of his tanks and trucks.)

FIDDLY BITS: D-DAY, THE 6th OF JUNE, 1944

- NAVAL BOMBARDMENT: 800 naval guns were arrayed on a 50 mile firing-line; 616 Allied ships fired 140,000 shells, and did virtually no damage to the German defenses- especially on Omaha Beach (did anyone think to ask the Marines in the Pacific about pre-invasion bombardment?)

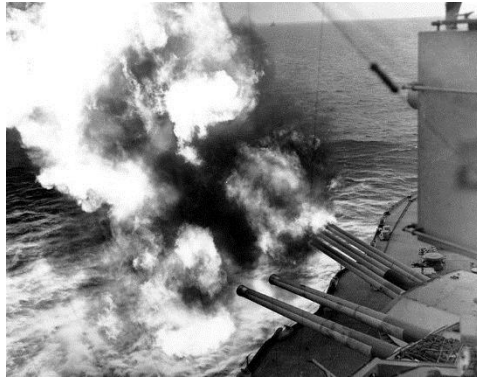

- * OMAHA BEACH: there were 85 machine gun nests, three times the number on the three British / Canadian beaches combined; the G.I.'s dubbed them "murder-holes"; it's been reported that one MG 42 gunner fired over 10,000 rounds. When asked why he stopped? His reply was: "Because I ran out of ammunition"; in the tidal area run up to the beach were 3,700 mined pilings and barriers; on shore there were 35 pillboxes, 8 massive bunkers, 18 anti-tank sites on the five exits; six Nebelwerfer pits; four artillery positions; and 13,000 soldiers of the 352nd Division thought to be twenty miles away in St. Lo; so instead of the planned 3 to 1 American advantage in men assaulting Omaha, it was a 3 to 5 advantage for the defending Germans. It's never a good thing for the attacker to be outnumbered by the defender. An IQ SNAFU.

- * At 56 a former President's son was the oldest man to land in the first wave of D-Day. Gen. Teddy Roosevelt, Jr. was the assistant division commander of the 4th Division which landed - in the wrong spot - on Utah Beach. For his heroics in overcoming this setback, and his valorous leadership Roosevelt would earn the Medal-of-Honor, and be rewarded further by Gen. Bradley with command of the troubled 90th Division. Tragically he died of a heart attack on July 12th before he learned of either award. But at least he got to see his son Quentin one last time, and fittingly it was on the last day of his life.



- * Actor Charles Durning landed on Omaha Beach with the 1st Division, was wounded, recovered and served in the Battle of the Bulge. My two favorite roles he played were in 'The Sting' and 'Tootsie'. You may remember Frank featured Durning in a Hollywood Heroes column.

- * OVERLORD OVERSIGHT: SHAEF planners were either unaware of Normandy's 'Bocage' country, or more focused on the initial landings and didn't pay attention to the hedgerows that made offensive

FIDDLY BITS: D-DAY, THE 6th OF JUNE, 1944

fighting next to impossible. St. Lo was supposed to be captured in the first few days after the landing. But it took until the middle of July to go the twenty miles from the beach to St. Lo. A major mistake by SHAEF, and costly in lives lost. Another IQ SNAFU.

* AMERICAN INGENUITY; A Sergeant Curtis G. Culin (102nd Cavalry Reconnaissance Squadron; N.J. Nat'l Guard a.k.a. "Essex Troop". 2nd Armored Division) cut up the metal beach obstacles and welded them on tank transmission covers which made them into hedgerow cutters.* I'm sure you tank modelers have at least one Sherman or Stuart with hedge row cutters. Right?



* WHERE WAS THE LUFTWAFFE?: The Germans lost 13,000 planes in the 5 months before D-Day; I didn't have this stat handy before I wrote my column in last month's newsletter; but it proves my point that the Luftwaffe was "kaput" before June 6th; there were 319 German aircraft available on D-Day, versus 13,000 Allied; NOTE: "Pips" Priller of "The Longest Day" fame ("longest day" is attributed to Rommel) was not the only German pilot over the beaches- but they posed no real threat. However, a high altitude Arado 234 jet recon plane did overfly the beach, taking pictures of the landing which I'm sure shocked the hell out of the German High Command.

* THE (NOT SO) IMPENETRABLE ATLANTIC WALL, a.k.a. "Rommel's Belt:" from Holland to the Loire River - the Atlantic Wall had 20,000 coastal fortifications; 500,000 offshore obstacles; 6.5 million mines; (the new German magnetic mines played havoc with Allied shipping); Rommel actually wanted 200 million mines. And it was overcome on all five beaches within hours, with Omaha being the last to be breached by early that afternoon. Historian Stephen Ambrose called it the most colossal waste of men and materials in the 20th Century. It stopped nobody.



** By Operation Cobra 60% of 1st Army tanks were "Rhino tanks"; a soldier named Roberts came up with an idea that Culin put in place. Culin was awarded the Legion of Merit (Source: Mentioned by Eisenhower in a 1964 interview with Walter Cronkite on the 20th Anniversary of D-Day).*

FIDDLY BITS: D-DAY, THE 6th OF JUNE, 1944

* ALLIED PRE-INVASION BOMBING CAMPAIGN: 71,000 tons of bombs were dropped on the French and German rail systems; this caused train traffic in France to diminish by 60%; 45,000 armed German rail workers were sent to France to help counter the French Resistance fighters blowing up the tracks, and to run the trains; 30,000 workers from the Atlantic Wall were sent to help repair the rail lines.



* By the full moon on the night of June 6th, 156,000 Allied soldiers were in France.

* By 9:15 pm the first airstrip in France was made ready behind Utah Beach, the first of 241 constructed in Europe through the end of the war.

* Only 100 of the scheduled 24,000 tons of supplies made it onto the beach on D-Day.

- * FRENCH CIVILIAN CASUALTIES: 3,000 Normans are killed in the first two days of the fighting; 15,000 are killed in the pre-invasion tactical bombing campaign.
-
- * RECKONING: the eight Allied assault divisions suffer 12,000 casualties; 8,230 were American; the wounded are the first of 400,000 Americans that are wounded in combat from June through VE-Day; their wounds lead to 7,000 amputations; and among the wounded are 89,000 fractures that need to be treated as well.



FIDDLY BITS: D-DAY, THE 6th OF JUNE, 1944

- * ALLIED AIRCRAFT LOST ON JUNE 6th: only 127 (out of 15,000 sorties.)
- * OPERATION COBRA: the Operation is to break out of the beachhead lodgment and capture the road net running through St. Lo for Patton's 3rd Army (and its breakout to eventually liberate Paris); 2,000 Allied bombers drop 5,000 tons of ordinance; 2% fall short, killing 111 American soldiers and wounding 490; also killed by (un-)"friendly fire" is Lt. Gen. Leslie McNair- all that they found to send home to his wife were six Lt. Gen. stars.
- * DEATH OF GERMAN GENERALS: Gen. Erich Marcks was KIA on June 12th when his staff car was strafed by "Jabos" (fighter bombers) outside of Carentan; during WWII 675 German Generals will die: 223 in action; 64 by their own hand (Rommel & Model); and 53 will be executed, either by the Reich or by death sentences carried out from war crime trials.
- * SUMMARY: By the end of August, 1944 there are 2 million Allied soldiers in France which gives them a 2 to 1 edge over the Germans in combat troops; the Allies have 438,000 vehicles and a 20 to 1 advantage in tanks over the Germans; AIR POWER: the USAAF and the RAF have 7,500 bombers and 4,300 fighters combined; these are attacking over an ever shrinking territory with the added advantage of the ability to reach safety if suffering any combat damage.
- To me it was an amazing example of logistical organizational skill, leadership, and the ability to adapt to changing circumstances. Did everything go according "to Hoyle". Certainly not. But by and large it was- to borrow from FDR - a "Mighty Endeavor". And to borrow as well from Tom Brokaw and Winston Churchill: "This was the Greatest Generation's Finest Hour" !
- (From Butch and Sundance: "Who were those guys?")



Hollywood Heroes



By Frank Ahern

This continuing feature is designed to showcase the often-unpublicized military service of many of the entertainment icons of the previous generation who served their country without complaint or protest.

James Doohan

At the beginning of the WW2, Doohan joined the Royal Canadian Artillery. He was sent to England in 1940 for training. He first saw combat at Juno Beach on D-Day. Shooting two snipers, Doohan led his men to higher ground where they took defensive positions for the night. Crossing between command post Doohan was hit by six rounds fired by a Canadian sentry.

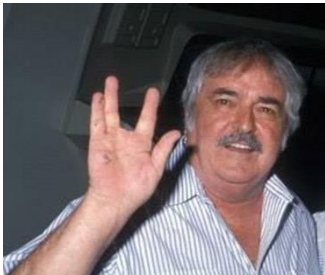

His right middle finger had to be amputated, something he would conceal on-screen during most of his career as an actor. Although he was never actually a member of the Royal Canadian Air Force, Doohan was once labelled the "craziest pilot in the RCAF. (see photo of Auster) In the late spring of

1945, he flew a Taylorcraft Auster between 2 telegraph poles "to prove it could be done" —earning himself a serious reprimand



Hollywood Heroes

James Doohan

Like many WW2 vets, Doohan started his career in radio. His talent for imitating accents led to many roles in radio dramas in the early 1950's. He eventually made the jump to TV and his choice of a Scottish accent landed him the role of chief



engineer Scott (Scotty with tribbles) in the original Star Trek TV series. “Beam me up Scotty” became an iconic phrase in the culture. After his death in 2005 and several failed attempts, his ashes were launched into space in 2012. (see photo of SpaceX launch)



Show and Tell



Andrea 1/32 "United States Cavalry to the Rescue"



Jack Muga's 1/48 Hasagawa Grumman F6F Hellcat



Allen Kuffman's 1/72 Academy SPAD S.XIII

Show and Tell



Jack Muga's 1/48 Tamiya General Dynamics F-16 Fighting Falcon



Bruce Doyle's 1/72 Sikorsky H-5



Frank Ahern's 1/48 Douglas C-47 Skytrain "Berlin Airlift"



Find more photos at: <https://www.flickr.com/photos/164030540@N04/albums/72157708808641057>

Show and Tell

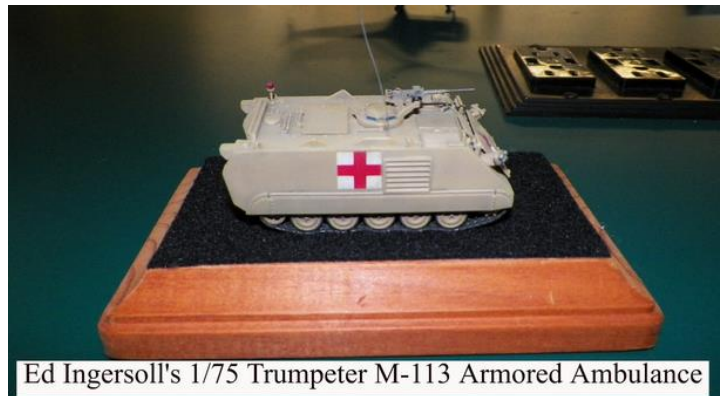

Find more photos at: <https://www.flickr.com/photos/164030540@N04/albums/72157708808641057>

Bill's Column

By Bill Winter

Serving as the Editor of this newsletter, I have spent more time writing and composing articles than building models in the last 6 months. This is not good . . . ☹️. However while traveling for work, I have read several books that may be of interest to my fellow modelers. 😊

Adapted from: <https://www.amazon.com/Raven-Rock-Governments-Secret-Itself-While/dp/1476735409>:

Raven Rock by Garrett M. Graff is the eye-opening true story of the government's secret plans to survive and rebuild after a catastrophic attack on US soil—a narrative that spans from the dawn of the nuclear age to today.

A short excerpt from the NYT's review includes: *Over drinks with the screenwriter Aaron Sorkin one evening, George Stephanopoulos — then serving as a policy adviser in the Clinton administration — pulled a card out of his wallet with details about how he would be evacuated from Washington in the event of a nuclear emergency. Sorkin later incorporated the card into an episode of his television show “The West Wing.” But Dee Dee Myers, Clinton's first press secretary, who went on to work as a consultant on the show, warned Sorkin that the plot was unrealistic since no such cards existed. They did, of course — but that had been a tightly guarded secret, and Myers had simply never received one. Not everyone could be evacuated, after all, and wonks evidently took precedence over flacks.*

That is just one of the many comically macabre anecdotes that Garrett M. Graff shares in “Raven Rock,” a thorough investigation of Washington's longstanding efforts to maintain order in the face of catastrophe. In exploring the incredible lengths (and depths) that successive administrations have gone to in planning for the aftermath of a nuclear assault, Graff deftly weaves a tale of secrecy and paranoia. The goal of “continuity of government” — an official euphemism for keeping the American state alive even if almost every American citizen ends up dead — has raised enormous ethical, bureaucratic and engineering challenges for generations of planners. Who would be saved? (Many federal officials, but generally not their families — a decision that has frequently been met with dismay.) From what branches of government? (Planning has often prioritized the executive branch over Congress and the courts.) And where would they go? (Underground, mostly.)

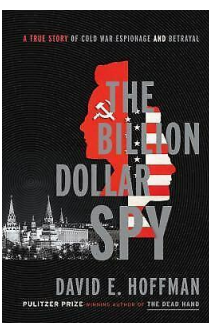
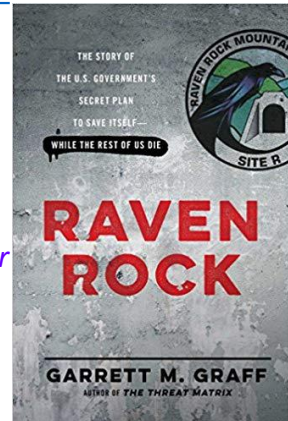

The next book I'd recommend is “**The Billion Dollar Spy**” by David E. Hoffman. From: <https://www.amazon.com/Billion-Dollar-Spy-Espionage-Betrayal/dp/0345805976>:

It was the height of the Cold War, and a dangerous time to be stationed in the Soviet Union. One evening, while the chief of the CIA's Moscow station was filling his gas tank, a stranger approached and dropped a note into the car. The chief, suspicious of a KGB trap, ignored the overture. But the man had made up his mind. His attempts to establish contact with the CIA would be rebuffed four times

Bill's Column



*he thrust upon them an envelope whose contents would stun U.S. intelligence. In the years that followed, that man, **Adolf Tolkachev (photo left)**, became one of the most valuable spies ever for the U.S. But these activities posed an enormous personal threat to Tolkachev and his American handlers. They had clandestine meetings in parks and on street corners, and used spy cameras, props, and private codes, eluding the ever-present KGB in its own backyard—until a shocking betrayal put them all at risk.*

The book title comes from the fact that the information provided to the U.S. by Tolkachev saved the U.S. billions and billions of dollars and improved our abilities to anticipate Soviet developments.

Now that we are nearing the 50th anniversary of man first walking on the moon, a great read is **"First Man"** by James R. Hansen. From this extremely detailed book we learn not only about Neil Armstrong but also learn about the early space program. Armstrong was first an engineer (yes, he did his "home work"), second a pilot (in my opinion), third, an astronaut and fourth, a teacher. He was quiet, spoke only when he needed to, was not vain or flashy. ... a life that we might all try to emulate despite his faults (he was a human nonetheless, and to err is "human").

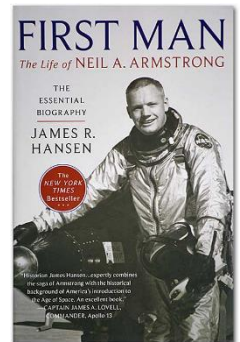

I would also argue that reading this book can interest one in modeling space craft (which I have sadly neglected except for building Monogram's 1:144 scale Saturn V rocket.



If you like books about space, other books that I've read that I would highly recommend include: **"Failure Is Not An Option"** by Gene Kranz, **"The Last Man on the Moon"** by Gene Cernan and **"Lost Moon: The Perilous Voyage of Apollo 13"** by Jim Lovell. About 20 years ago, Nancy (my wife), Will (our son) and I got to spend a weekend with Barbara Cernan, Gene Cernan's first wife. I **KNEW** I was in the presence of royalty in visiting with Barbara.

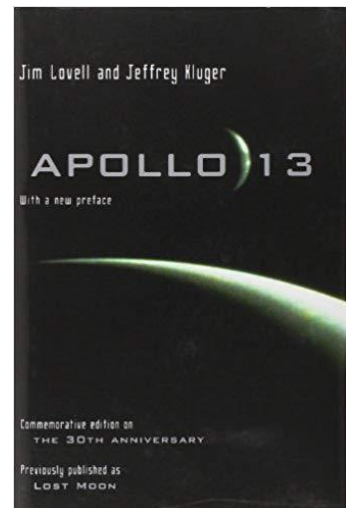
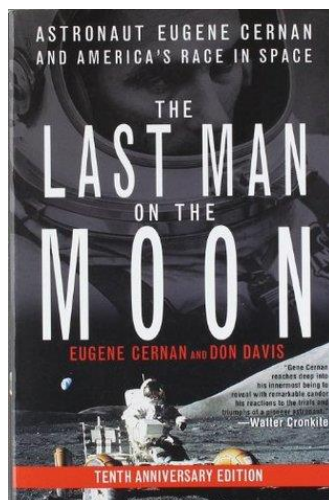
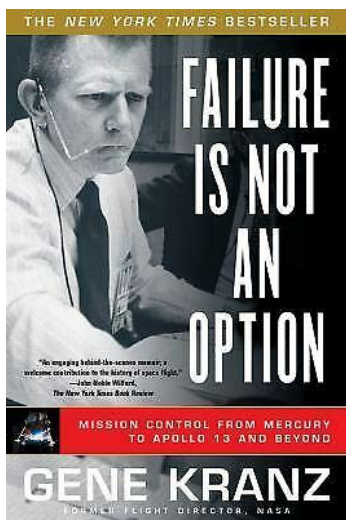

Odds and Ends Contributed by Club Members & Friends

Submitted by Paul Bennett –

Check Out The Latest Video: http://finescale.com/videos/new-product-rundown/2019/05/new-product-rundown-159-video-review-roden-c133?utm_source=Yesmail&utm_medium=email&utm_campaign=News0_FSM_190522_00000

In this episode of the New Product Rundown, Aaron Skinner and Elizabeth Nash, plus Scale Auto's Tim Kidwell, take a look at 4 new kits:

- **Roden's 1/144 scale C-133 Cargomaster**
- Roden's 1/35 scale WWI BL 8-inch howitzer
- MPC's 1/25 scale 1977 Pontiac Firebird Trans Am
- AMG's 1/48 scale Hawker Hart Mk.I



I got the kit in a few days ago. Did a web search and here is a written review. After looking at the 1/144 scale C-141B kit...

Good Heavens!!! the kit has a 1/144 scale cockpit!

I thought it was gonna be flat black paint time.

And then there was the version modified with clamshell doors so it could carry ICBM's

Paul

.... **Forgot to add the link.**

<https://modelpaintsol.com/reviews/roden-144th-douglas-c-133a-cargomaster-333>

Paul

AND ----- > Folks

Just a heads up to keep in mind when travelling. Recently the Florida Department of Transportation has extended their "Road Ranger" service to I-75 and I-10. They help with minor car problems and break downs. They can be contacted through *347 (*FHP) and are dispatched through the Florida Highway Patrol.

Odds and Ends Contributed by Club Members & Friends

... From Bill Winter – If you fly into Dulles and have half a day, consider visiting the Udvar-Hazy Air and Space Museum. If you are a senior citizen, you can take bus #983 from the Airport to the Museum for \$1.00. What a bargain!

981-983
Effective January 24, 2015

Dulles Airport – Udvar-Hazy Center – Wiehle-Reston East

Wiehle-Reston East Metro Station • Reston Town Center Transit Station • Herndon/Monroe Park & Ride • Dulles Airport • Udvar-Hazy Air & Space Museum

Weekday, Saturday & Sunday Service

FAIRFAX CONNECTOR

For fares and important information about the bus system, see the brochure: **Fares, Policies & General Information**

FAIRFAX CONNECTOR BusTracker
REAL-TIME SERVICE INFORMATION
fairfaxconnector.com

703-339-7200 TTY 703-339-1608
@fairfaxconnector fairfaxconnector

* See exact fare if there do not carry change.
* Some fare setting, boarding, and lifting may vary by route.
* This is a County Department of Transportation (CDOT) program. Information is all programs and activities in accordance with Title VI of the Civil Rights Act of 1964 and for information with the Office of ADA. To request this information in an alternate format, contact FADA at 703-607-5800, TTY 771-1111.



Godzilla is still popular!



How about a 1/16 scale '55 Chevy!

'55 CHEVROLET

Model: redbut your assembler/disassembled hobby kit

BEL AIR CONVERTIBLE

BIG 1/16 SCALE

am

OPENING DOORS AND HOOD • VINYL HOSES AND WIRING • STOCK VERSION PLUS CUSTOM PARTS • MODEL 12" LONG ASSEMBLED

Odds and Ends Contributed by Club Members & Friends

... From Jack Muga



SEE the PREVIEW!!!!

<https://www.youtube.com/watch?v=3asRWZaGCQk&feature=youtu.be&fbclid=IwAR2BhndIH5IJN0IRS08mIO3wr2VS65zvK4hluKu1KegTEYDgd0KXhUUhYes>

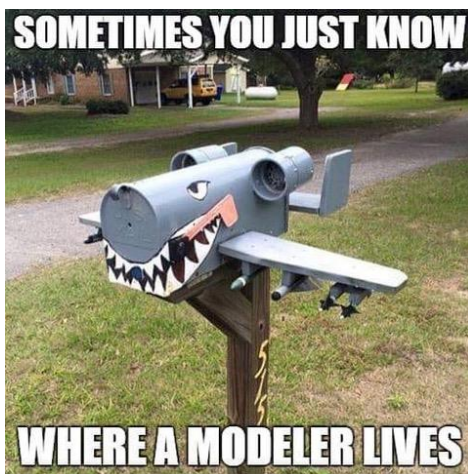

It seems like we've been hearing about a movie covering Ford vs Ferrari at Le Mans in the 1960s for years, but now, it finally has a release date. Walt Disney Studios, following its recent acquisition of Fox's film business, [announced yesterday that Ford v. Ferrari](#) would be released on November 15th this year.

FROM: <https://www.roadandtrack.com/car-culture/entertainment/a27407427/ford-v-ferrari-christian-bale-matt-damon-release-date/>

... 2012 NordiCon: <https://www.pauloimodelworks.com/nordiccon-2012-part-1/>

<https://www.youtube.com/watch?v=jBER3XsIC58> – Speed Week 2018

EA-6A build: <https://www.youtube.com/watch?v=8K4NyQBSAns>

Odds and Ends Contributed by Club Members & Friends

... From **Jack Mugan**

... .95+ Unbelievable Realistically Depicted Scale Models That Come To Life:

<https://homesthetics.net/unbelievable-scale-models-that-come-to-life/>



... From **Ed Ingersoll**: <https://www.beyondbandofbrothers.com/>

Flying an obsolete plane to greatness

Marmaduke Thomas St. John "Pat" Pattle (1914-1941) was the highest-scoring Western Allied ace in World War II. The exact number of his victories is unknown, since Allied records were lost or destroyed during the fall of Greece. His score was at least in the 30s, but later research suggests it might have been over 40, or even 50.



Odds and Ends Contributed by Club Members & Friends

Submitted by Joe Caputo



... From Jack Mugan



... a 3-D De Havilland Hangar

https://my.matterport.com/show/?m=4MzndpKdT2T&fbclid=IwAR1UW0ZeLpCYkvyuAAAYFvwy1b6Ku7vsCn33BcKp9tmkQgqd_5jyV6RoeoQ&utm_source=4

An **Italian** show:

<https://www.facebook.com/photo.php?fbid=2547884155243787&set=a.2547883405243862&type=3&theater>



Odds and Ends Contributed by Club Members & Friends

... From Jack Mugan
this kit does NOT exist. ☹️



neither does this kit exist.

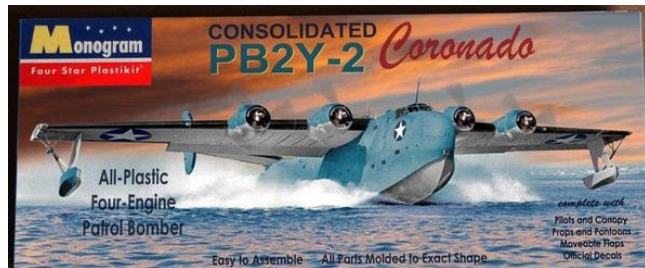

.... From Paul Bennett: I found this on the web. <http://www.nycfiremuseum.org/>



Also if you like Vette's (and have lots of \$\$) (from Ed Ingersoll):

https://urldefense.proofpoint.com/v2/url?u=https-3A__www.bnamodelworld.com_model-2Dcars-2Dmotorcycles-2Dparts-2Ddecals-2Dscale-2Dmotorsport-2Dsms-2D2050&d=DwIFAg&c=sJ6xIWYx-zLMB3EPkvcnVg&r=jzlfSSorEPNo37OXhPxyKgCet5y6tQ2EZ0WULQcGYH4&m=nffrVT6lcw6rE_GcXoKN-cYKb9Oe37brAEhn80SdcqM&s=triatvPH63ZwN4qIAKS1p_m3MmOhxAL3jj9Fv9Er_ng&e=

1/25 Corvette C7R Super Detail Kit for Revell kit #85-2016

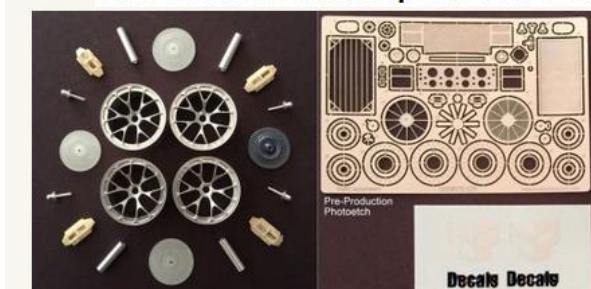

SKU:	SMS 2050
Price:	US\$177.25 US\$177.25; €152.14
earn:	243 BNA points
Availability:	 In Stock
Order Quantity: <input type="text" value="1"/>	

Odds and Ends Contributed by Club Members & Friends

... From **Fred Horky** (*friend of many, many clubs*) to **Frank Ahern**

... . . . It's Oh-Dark-Hundred, I woke up and can't get back to sleep, so I decided to write to say how much I enjoyed your **Berlin Airlift** piece in the latest Gator newsletter.

My writing will probably be pretty spastic, as it's from an iPad balanced on my knee while in a hospital bed. (I'm in a rehab facility after surgery; I fell and badly broke an ankle a while back.)

But about the airlift. It was ten years before my time, of course, but I did get checked out to fly the corridors on two separate occasions. (Worth noting is that every time you might be back on a different tour/aircraft, you had to get requalified: it was VERY sensitive business!)

The first was when in a Mace missile outfit at Sembach in Germany, flying Ye Olde Gooney Bird (**C-47**, in 1960) and again when back in Europe in 1964 with a **C-130** "rotation" squadron on temporary duty in France. (Evreux Air Base. Le Grand Charles (deGaulle) kicked us out of France a year or two later. Evidently he thought the danger of the Germans coming back ...again ... had subsided.)

Flying the corridors was everything you said and more. Not particularly difficult, but the penalties for mistakes were so much more! And the weather really was the biggest adversary. We were told that on average, the flying weather at the WORST stateside USAF base was still better than the BEST USAFE (U.S. Air Forces in Europe) base.

My last flight into Berlin was with a Herk; a midnight-alarm thing where we arrived in the wee hours with the fog clamped down on Tempelhof. I'll never forget breaking out of the crud right at GCA (ground-controlled approach) minimums (memory says 200' and a half mile viz), over the famous cemetery off the east end of the runway, the taller monuments stark white in the landing lights seemingly reaching up to scratch the belly of our Herk; while in the corner of my eyes I could see the lights in the upper-floors of apartment buildings on either side sliding by AT EYE LEVEL.

About Berlin: in 1960, WEST Berlin was recovering rapidly, while EAST Berlin was still largely rubble. We were able to visit the latter on controlled tours. The contrast between capitalism and communism couldn't have been starker. I was in Germany when they BUILT their damn wall, so I got to see it before and after. Since, I've often wished that every American could stand at Checkpoint Charlie and gaze over the wallit was a visceral feeling ...like looking into a giant prison, which I suppose is what it actually was.

Thanks for stirring the memories!

Fred



... From **Joe Caputo**

LUFTWAFFE

RLM 02--> XF22:1 + XF49:1 or just XF-22

RLM 65--> XF23:1 + XF2:1

RLM 71--> XF62:1 + XF49:1

RLM 74--> XF24:3 + XF27:2

RLM 75--> XF24:5 + XF50:1

RLM 76--> XF2:7 + XF23:1 + XF66:2

RLM 79--> XF59:3 + XF64:1

RLM 80--> XF58

RLM 81--> XF51:1 + XF64:2

RLM 82--> XF5 or XF5:1 + XF2:1 or XF5:1 +XF3:1 (Bright Green)

RLM 83--> XF61 or XF24:1 + XF51:1 or XF24:1 +XF51:1 (Dark Green)

Tamiya instruction sheets:

LUFTWAFFE

RLM 02:- XF22:1 + XF49:1 or just XF-22

RLM 65:- XF23:1 + XF2:1

RLM 70: XF27

RLM 71:- XF62:1 + XF49:1

RLM 74:- XF24:3 + XF27:2

RLM 75:- XF24:5 + XF50:1

RLM 76:- XF2:7 + XF23:1 + XF66:2

RLM 79:- XF59:3 + XF64:1

RLM 80:- XF58

RLM 81:- XF51:1 + XF64:2

RLM 82:- XF5 or XF5:1 + XF2:1 or XF5:1 +XF3:1 (Bright Green)

RLM 83:- XF61 or XF24:1 + XF51:1 (Dark Green)

RLM 78:- XF-23:4 and XF-50:1

From other modelers:

RLM 71 XF 61 Dark Green Straight

RLM 78 is a close match to FS 35414. Use Tamiya XF23 light blue and add white. I think the formula I have is 3 parts XF23 to 1 part XF2.

RLM 02: XF22:1 + XF49:1 + XF2:2

RLM 65: XF23:2 + XF2:1

RLM 66: XF24 Straight from the bottle.

RLM 70: XF27 Straight from the bottle. Add a drop of black to darken if desired.

RLM 71: XF62:1 + XF49:1 or XF61:3 + XF2:1 or XF81 straight from the bottle.

RLM 74: XF24:3 + XF27:2

RLM 75: XF24:5 + XF50:1

RLM 76: XF2:7 + XF23:1 + XF66:2

RLM 78: XF23:4 + XF50:1

RLM 79: XF59:3 + XF64:1

RLM 80: XF58:6 + XF2:1

RLM 81: XF51:1 + XF64:2 OR Dunkelgrun = XF61:4 + XF2:1 (FS34096)

RLM 82: XF5:1 +XF3:1 (Bright Green)

RLM 83: XF5 Straight from the bottle.

RAF:

INTERIOR GREEN--> XF5:1 + XF21:3 + XF65:1

DARK GREEN--> XF58:1 + XF62:5

DARK EARTH--> XF52:1 + XF64:1

OCEAN GRAY--> XF18:1 + XF21:2 + XF24:2

MIDSTONE-----> XF59:1 + XF60:1

SKY-----> XF21:1 + XF2:1.5 (from Roy Sutherland)

**Odds and Ends
Contributed by
Club Members &
Friends**

Odds and Ends Contributed by Club Members & Friends

... From **Joe Caputo**

MED. SEA GRAY--> XF19:3 + XF54:5
AZURE BLUE--> X16:2 + XF2:10 + XF18:5
FAA COLORS

Extra Dark Sea Grey: To 50 parts of XF24 (dark grey), add 6 parts XF2 (white), and 3 parts XF8 (flat blue). (Thanks to Roy Sutherland for this recipe)

Dark Slate Grey: To one bottle of XF22 (RLM Grey), add 35 drops of XF7 (red), and 125 drops of XF1 (flat black). or T:XF-11 + 63? (Thanks to Roy Sutherland for this recipe)

"RLM Grey" (XF-22) is a good match for "Slate Grey", used for RAF Coastal Command finishes, as well as Fleet Air Arm colors.

"Dark Sea Grey" (XF-54) is a good match for "Dark Sea Grey," used for Coastal Command and FAA camouflages. This is also good for the US "Equivalent Color" for "Ocean Grey" ANA 603, used on Mustang III's, etc.

"RLM Gray" (XF-22) for "Slate Grey"

"Light Sea Grey" (XF-25) for "Light Sea Grey"

"Sky" (XF-21) - I think this is the most accurate version of this color.

"Sky Grey" (XF-19) is perfect for the "Sky Grey" color used on FAA aircraft before they went with the "Sky" lower surfaces, also for the US "Equivalent Color" used for ANA 602

"Medium Grey" (XF-20) is good as "Sea Grey Medium," the lower surface camouflage for RAF aircraft after 1941.

Here are Tamiya mixes to reproduce some Federal Standards (FS) Colors.

Last updated: 2012-08-11

The hyperlink included with the colors sends you to the Federal Standard 595 Color Server website to give you an idea of how the colors look.

The mix ratios are by parts, i.e. XF2:1 means XF2 Flat White 1 part (1 drop or 1 gallon, the mix stays the same)

Warning: Several mixes I've tested myself (those with an *) but most of them come from Tamiya instructions, articles found in magazines and the web. I find them good but these are in no way definitive. They serve as a general guide that you can modify to taste.

Scale effect: for those who believe, the smaller the scale, the lighter the colors. These mixes are formulated for 1/32 but you can add XF2:1 for 1/48 or XF2:2 for 1/72 as a start. Lighten to taste.

Browns X0XXX

*30051 US NATO Brown CARC 383 -- XF10:6+ XF69:1

<http://www.colorserver.net/showcolor.asp?fs=30051>

20061 -- Tea Brown (WW2 Japan Propeller) -- X9 Brown:6 + XF7 Red:3 + XF1:1

<http://www.colorserver.net/showcolor.asp?fs=20061>

30070 -- RAL 8017 WW2 German Red Grown -- XF-64:8 + XF-49:2

<http://www.colorserver.net/showcolor.asp?fs=30070>

30075 -- XF79

<http://www.colorserver.net/showcolor.asp?fs=30075>

30108 -- Red Brown -- XF-10

<http://www.colorserver.net/showcolor.asp?fs=30108>

30111 -- XF68:3 + XF2:1

<http://www.colorserver.net/showcolor.asp?fs=30111>

30117[/[color](#)] -- MERDC Brown -- XF64:1 + XF2:1

<http://www.colorserver.net/showcolor.asp?fs=30117>

[b]30118 -- RAF DARK EARTH

*Mix 1--XF-52:1 + XF64:1 + XF-2:1

*Mix 2--XF-52 (Tamiya Spitfire VIII 1/32 instruction)

*Mix 3--XF-52:4 + XF-3:2+ XF-51:1 + XF-2:1

<http://www.colorserver.net/showcolor.asp?fs=30118>

30140 -- XF52:1 + XF64:1 (Tamiya F-16 Agg 1/48 Instructions)

<http://www.colorserver.net/showcolor.asp?fs=30140>

... From **Joe Caputo**

*30145 -- XF52
<http://www.colorserver.net/showcolor.asp?fs=30145>
*30219 -- RLM 79 -- XF59:6 + XF64:2 + XF2:1
<http://www.colorserver.net/showcolor.asp?fs=30219>
30257 -- Australian Army
*Mix 1 -- XF52:2 + XF15:2 + XF2:1
*Mix 2 -- (MERDC Pale Brown) -- XF-52:1 + XF57:8
<http://www.colorserver.net/showcolor.asp?fs=30257>
30266 -- RAF MIDSTONE -- XF59:1 + XF60:1+ XF-2:1
<http://www.colorserver.net/showcolor.asp?fs=30266>
30277 -- MERDC Sand -- XF57:4 + XF63:1
<http://www.colorserver.net/showcolor.asp?fs=30277>
30279 -- XF79:9 +XF7:1
<http://www.colorserver.net/showcolor.asp?fs=30279>
30318 -- XF57
<http://www.colorserver.net/showcolor.asp?fs=30318>
30400 -- XF15:1 + XF2:1 + XF59:1 (Tamiya F-16 Agg 1/48 Instructions)
<http://www.colorserver.net/showcolor.asp?fs=30400>
Reds X1XXX
*FS 31668 -- PRU Pink -- XF9:1 + XF7:1 + XF2:9
<http://www.colorserver.net/showcolor.asp?fs=31668>
Oranges X2XXX
22300 -- Orange-yellow japan (trainer/experimental) -- X8:18 + X7:1
<http://www.colorserver.net/showcolor.asp?fs=22300>
32519 -- XF15:3 + XF55:1
<http://www.colorserver.net/showcolor.asp?fs=32519>
Yellows X3XXX
33245 -- RAL 8000 WW2 German Africa Yellow -- XF-49:8 + X-6:1 + XF-2:2
<http://www.colorserver.net/showcolor.asp?fs=33245>
33303 -- XF60:3 + XF2:1
<http://www.colorserver.net/showcolor.asp?fs=33303>
33481 -- RAL 7028 WW2 German Dark Yellow -- XF60:7 + XF2:3
<http://www.colorserver.net/showcolor.asp?fs=33481>
33522 -- RAL 7028 End of war -- XF-20:1 + XF-2:4 + 1 tiny drop of red
<http://www.colorserver.net/showcolor.asp?fs=33522>
Greens X4XXX
34036 -- Nakajima Dark Green (Navy) -- XF11:5 + XF2:1
<http://www.colorserver.net/showcolor.asp?fs=34036>
34050 -- RLM 70 -- XF27:4 + XF2:1
<http://www.colorserver.net/showcolor.asp?fs=34050>
34052 -- RLM 80 -- XF58:6 + XF2:1
<http://www.colorserver.net/showcolor.asp?fs=34052>
34056 -- WW2 Soviet -- XF-61:7 + XF-60:3
<http://www.colorserver.net/showcolor.asp?fs=34056>
34058 -- (Tamiya F-16 Agg 1/48 Instruction) -- XF-70
<http://www.colorserver.net/showcolor.asp?fs=34058>
34077 -- J.A. Green -- XF-13
<http://www.colorserver.net/showcolor.asp?fs=34077>
34079 -- RAF DARK GREEN
*Mix 1 -- XF58:1 + XF62:5 + XF-2:1
*Mix 2 -- New Tamiya Color: Dark Green 2 (RAF)-- XF-81
*Mix 3 -- RLM 71 -- XF62:1 + XF49:1 + XF2:1

**Odds and Ends
Contributed by
Club Members &
Friends**

. . . From **Joe Caputo**

*Mix 3 -- RLM 71 -- XF62:1 + XF49:1 + XF2:1
*Mix 4 -- XF61:1 + XF65:1 + XF2:1
<http://www.colorserver.net/showcolor.asp?fs=34079>
34083 -- RAL 6003 WW2 German Dark Green -- XF-61:7 + XF-60:3
<http://www.colorserver.net/showcolor.asp?fs=34083>
34084 -- RLM 74 -- XF24:2 + XF-51:1 + XF27:1 + XF2:4
<http://www.colorserver.net/showcolor.asp?fs=34084>
34086 -- RLM 74 (variation) -- XF24:2 + XF27:1 + XF2:3
<http://www.colorserver.net/showcolor.asp?fs=34086>
34088
Mix 1 -- RLM 81 -- XF61:5 + XF-7:1 + XF2:2
Mix 2 -- WW2 UK+Canada Armor -- XF-62:6 + XF-49:4
<http://www.colorserver.net/showcolor.asp?fs=34088>
34092
Mix 1 -- Medium Green USAAF -- XF13:1 + XF2:1
Mix 2 -- XF26:3 + XF2:1
<http://www.colorserver.net/showcolor.asp?fs=34092>
*34094 -- CARC 383 Nato Green -- XF-67
<http://www.colorserver.net/showcolor.asp?fs=34094>
34096 -- Dark Green
Mix 1 -- Mitsubishi Dark Green -- X5:5 + XF3:3 + X3:2
*Mix 2 -- WW2 US Armor -- XF62:4 + XF49:1
*Mix 3 -- RLM 81 -- XF61:4 + XF2:1
<http://www.colorserver.net/showcolor.asp?fs=34096>
*34097 -- RLM 83 -- XF62:4 + XF2:1
<http://www.colorserver.net/showcolor.asp?fs=34097>
*34098 -- Cougar/Grizzly/Husky -- XF67:3 + XF59:2
<http://www.colorserver.net/showcolor.asp?fs=34098>
*34102 -- Forest Green -- XF5:3 + XF13:3 + XF2:1
<http://www.colorserver.net/showcolor.asp?fs=34102>
*34110 -- France Nato Green -- XF5
<http://www.colorserver.net/showcolor.asp?fs=34110>
34128 -- Australian Army -- XF-62:3 + XF-52:3 + XF-2:1
<http://www.colorserver.net/showcolor.asp?fs=34128>
34138 -- RLM 82 -- XF5:1 + XF3:1 + XF2:1
<http://www.colorserver.net/showcolor.asp?fs=34138>
34151 -- Loam Green MERDC -- XF5:1 + XF57:3
<http://www.colorserver.net/showcolor.asp?fs=34151>
*34159 -- XF73:3 + XF2:1
<http://www.colorserver.net/showcolor.asp?fs=34159>
*34172 -- Cougar Grizzly Husky -- XF70:1 + XF59:3
<http://www.colorserver.net/showcolor.asp?fs=34172>
*34201 -- XF-49:3 + XF2:1
<http://www.colorserver.net/showcolor.asp?fs=34201>
34227 -- RAF INTERIOR GREEN (vert intérieur)
*Mix 1 -- XF-71:1 + XF-21:1 + XF-2:1
Mix 2 -- XF5:1 + XF-21:3 + XF-65:1 + XF-2:1
<http://www.colorserver.net/showcolor.asp?fs=34227>
34255 -- Nakajima Interior grey-Green -- XF2:9 + X1:3 + X5:3 + X8:2
<http://www.colorserver.net/showcolor.asp?fs=34255>
34424 -- RLM 84 -- XF14
<http://www.colorserver.net/showcolor.asp?fs=34424>

**Odds and Ends
Contributed by
Club Members &
Friends**

... From **Joe Caputo**

34432 -- RLM 84 Variation -- XF12

<http://www.colorserver.net/showcolor.asp?fs=34432>

*34504 -- RAF SKY -- XF-21:1 + XF-2:1

<http://www.colorserver.net/showcolor.asp?fs=34504>

Blues X5XXX

15042 -- USN Glossy Sea Blue ANA 623 -- XF-17:1 + XF-8:1

<http://www.colorserver.net/showcolor.asp?fs=15042>

35045 -- USN NON-SPEC. SEA BLUE ANA 607 -- XF-17:5 + XF-8:3 + XF-2:2

<http://www.colorserver.net/showcolor.asp?fs=35045>

35052 -- XF8:9 + XF7:1

<http://www.colorserver.net/showcolor.asp?fs=35052>

35109 -- XF8:3 + XF2:4 (Tamiya F-16 Agg 1/48 Instruction)

<http://www.colorserver.net/showcolor.asp?fs=35109>

35164 -- USN INTERMEDIATE BLUE ANA 608 -- XF18:5 + XF-2:3

<http://www.colorserver.net/showcolor.asp?fs=35164>

35189 -- USN BLUE-GREY -- XF18:1 + XF-2:1

<http://www.colorserver.net/showcolor.asp?fs=35189>

35190 -- PRU BLUE -- XF18:1 + X14:2 + XF-2:2

<http://www.colorserver.net/showcolor.asp?fs=35190>

35231 -- RAF AZURE BLUE

*Mix 1-- X16:2 + XF-2:4

*Mix 2-- XF-8:1 + XF-2:3 (Tamiya Spit VIII 1/32 instructions)

<http://www.colorserver.net/showcolor.asp?fs=35231>

35237

*Mix 1 -- XF-66:1 + XF-19:1 + XF-2:2 +

*Mix 2 -- CF-18 -- XF66:1 + XF54:1 + XF2:2

<http://www.colorserver.net/showcolor.asp?fs=35237>

35250 -- XF8:5 + XF19:1 + XF2:5

<http://www.colorserver.net/showcolor.asp?fs=35250>

35352 -- RLM 65 -- XF23:4+ XF2:1

<http://www.colorserver.net/showcolor.asp?fs=35352>

35414 -- RLM 78 -- XF23:5 + XF54:1 + XF2:2

<http://www.colorserver.net/showcolor.asp?fs=35414>

35450 -- X14:1 + XF2:6 (Tamiya F-16 Agg 1/48 Instructions)

<http://www.colorserver.net/showcolor.asp?fs=35450>

35488 -- SU-27 -- XF8:5 + XF19:1 + XF2:10

<http://www.colorserver.net/showcolor.asp?fs=35488>

35526 -- XF8:1 + XF2:10 (Tamiya F-16 Agg 1/48 Instruction)

<http://www.colorserver.net/showcolor.asp?fs=35526>

35622 -- RLM 76 and 84(blue variation)

*Mix 1 -- XF18:1 + XF24:5 + XF2:10

*Mix 2 -- XF23:1 + XF2:3 (Tamiya F-16 Agg 1/48 Instruction)

<http://www.colorserver.net/showcolor.asp?fs=35622>

Greys X6XXX

36008 -- XF-63:9 + XF19:1

<http://www.colorserver.net/showcolor.asp?fs=36008>

36081 -- RAL 7021 Gris Panzer Allemand 1 (Dark) -- XF-63:7 + XF-60:3

<http://www.colorserver.net/showcolor.asp?fs=36081>

36118

*Mix 1-- RLM 74 -- XF-24:10 + X-14:1 + XF-2:1

*Mix 2-- RAL 7021 German Panzer Grey 2 (Pale) --XF-63:7 + XF-2:3

<http://www.colorserver.net/showcolor.asp?fs=36118>

**Odds and Ends
Contributed by
Club Members &
Friends**

... From **Joe Caputo**

36122 -- RLM 75 -- XF66:6+XF7:2+XF18:1+ XF2:2
<http://www.colorserver.net/showcolor.asp?fs=36122>
 36152 -- RAF OCEAN GRAY
 *Mix 1-- XF18:1 + XF-21:2 + XF24:2 + XF-2:1
 *Mix 2-- New Tamiya Color: Ocean Gray 2 (RAF)-- XF-82
<http://www.colorserver.net/showcolor.asp?fs=36152>
 36165 -- RLM 02- FS 36165 -- XF22:1 + XF49:1 + XF2:2
<http://www.colorserver.net/showcolor.asp?fs=36165>
 *36173 -- (Perfect for C-17 1/144) -- XF-54:3 + XF-24:1 + XF-2:4
<http://www.colorserver.net/showcolor.asp?fs=36173>
 36176 -- XF-66:3 + XF-2:1
<http://www.colorserver.net/showcolor.asp?fs=36176>
 36231 -- XF-83:1 + XF-66:1 + XF-54:1 + XF-2:3
<http://www.colorserver.net/showcolor.asp?fs=36231>
 36251 -- XF-83:3 + XF-2:1
<http://www.colorserver.net/showcolor.asp?fs=36251>
 36270
 *Mix 1-- XF54:6 + XF66:1 + XF2:6
 *Mix 2-- RAF MEDIUM SEA GRAY -- XF-19:3 + XF-54:5 + XF-2:1
 *Mix 3-- New Tamiya Color: Medium Sea Gray 2 (RAF) -- XF-83
<http://www.colorserver.net/showcolor.asp?fs=36270>
 36314 -- XF-19
<http://www.colorserver.net/showcolor.asp?fs=36314>
 36320
 *Mix 1-- XF-66:1 + XF-54:1 + XF-2:3
 *Mix 2-- XF19 (Tamiya F-16 Agg 1/48 Instructions)
<http://www.colorserver.net/showcolor.asp?fs=36320>
 36375 Light Ghost Grey
 *Mix 1-- XF-19:1 + XF-2:3
 *Mix 2-- CF-18 -- XF19:1 + XF54:1 + XF2:4
 *Mix 3-- Mitsubishi Light Gray FS26375 -- XF2:18 + XF1:1
<http://www.colorserver.net/showcolor.asp?fs=36375>
 36440 Light Gull Grey
 *Mix 1 -- XF-19:1 + XF-80:1 + XF-2:2
 *Mix 2 -- USN LIGHT GREY -- XF-19:2 + XF-2:1 (add a tiny drop of yellow)
<http://www.colorserver.net/showcolor.asp?fs=36440>
 36473 Light Aircraft Grey - RLM 76 -- XF23:1 + XF66:2 + XF2:7
<http://www.colorserver.net/showcolor.asp?fs=36473>
 36495 -- XF19:1 + XF2:4
<http://www.colorserver.net/showcolor.asp?fs=36495>
 36622 -- XF80:2 + XF2:7
<http://www.colorserver.net/showcolor.asp?fs=36628>
 36628 -- XF80:1 + XF2:4
<http://www.colorserver.net/showcolor.asp?fs=36628>
 ome Tamiya Mixes from Tamiya kit instructions:
 RAF
 INTERIOR GREEN:- XF5:1 + XF21:3 + XF65:1
 DARK GREEN:- XF58:1 + XF62:5
 DARK EARTH:- XF52:1 + XF64:1
 OCEAN GRAY:- XF18:1 + XF21:2 + XF24:2
 MIDSTONE:- XF59:1 + XF60:1

**Odds and Ends
 Contributed by
 Club Members &
 Friends**

. . . From **Joe Caputo**

SKY:- XF21
MED. SEA GRAY:- XF19:3 + XF54:5
AZURE BLUE:- X16:2 + XF2:10 + XF18:5
AS6 Olive Drab = XF-62
AS7 Neutral Gray = XF-53
AS8 Navy Blue = XF-17:5 + XF-8:3 + XF-2:2
AS9 Dark Green = XF-58:1 + XF-62:5
AS10 Ocean Gray = XF-18:1 + XF-21:2 + XF-24:2
AS11 Medium Sea Gray = XF-19:3 + XF-54:5
AS12 Bare-Metal Silver
AS13 Green
AS14 Olive Green
AS15 Tan
AS16 Light Gray
AS17 Dark Green (IJA)
AS18 Light Gray (IJA)
AS19 Intermediate Blue (U.S.Navy) = XF-18:5 + XF-2:4
AS20 Insignia White (U.S.Navy) = XF-2:10 + XF-55:1
AS21 Dark Green 2 (IJN)
AS22 Dark Earth = XF-52:1 + XF-64:1

.. . from Jack Muga: Good and FREE online aviation magazine
<https://www.wingleadermagazine.co.uk/issue1>

. . . . From AJ Kwan!

James Earl Rudder (May 6, 1910 – March 23, 1970) was a United States Army major general who as a lieutenant colonel was the commander of the historic **Pointe du Hoc** battle which was part of the Invasion of Normandy. He also commanded U.S. forces at the Battle of the Hurtgen wood and led a series of delaying actions and ambushes during the Battle of the Bulge. He was a graduate of Texas A&M College. General Rudder also at various times served as Texas Land Commissioner, the 16th president of Texas A&M University, third president of the Texas A&M University System, mayor of Brady, Texas, and a high school and college teacher and coach.

FYI. He was President of A&M when I attended and graduated from TAMU.

<https://www.americanrifleman.org/articles/2019/5/17/the-men-and-guns-of-pointe-du-hoc/>

. . . Available from David Doyle publishing

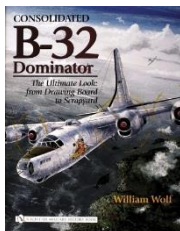

**Consolidated B-32 Dominator:
The Ultimate Look: from Drawing
Board to Scrapyard**

From Jack Muga . . . <https://www.youtube.com/watch?v=SwBK0a3n658&t=2060s>

Robin Olds!

**Odds and Ends
Contributed by
Club Members &
Friends**



... From **Ed Ingersoll**



Mr. Fold-It AG128

When Mr. Fold-it made its debut in 2003, Terry Ashley wrote this review on PMMS.

The set is small in size measuring just 76mm x 50mm (3inch x 2inch) and comes in a small plastic traveling case. The set is made entirely of hard ABS plastic and this may raise an eyebrow with all other etched bending tools being metal but it does work well.

Consisting of the base with four non slip feet that sit firmly on your work surface and a small head with five fingers of different sizes and the head can also be rotated to use the full length side for bending longer parts.

In celebration of M&Models upcoming anniversary from May 22 to June 5, Mr. Fold-it will be available to our customers for the fabulous price of \$10.99. This is a favorite of our military and customers who travel travel and like to bring small bits to work on while they are away from home.

<https://www.mmodelstore.com/search.aspx?manufacturer=18>

What is wrong with this cover of a recent Gainesville Sun tribute to the Allies success in D-Day? (answer next page).

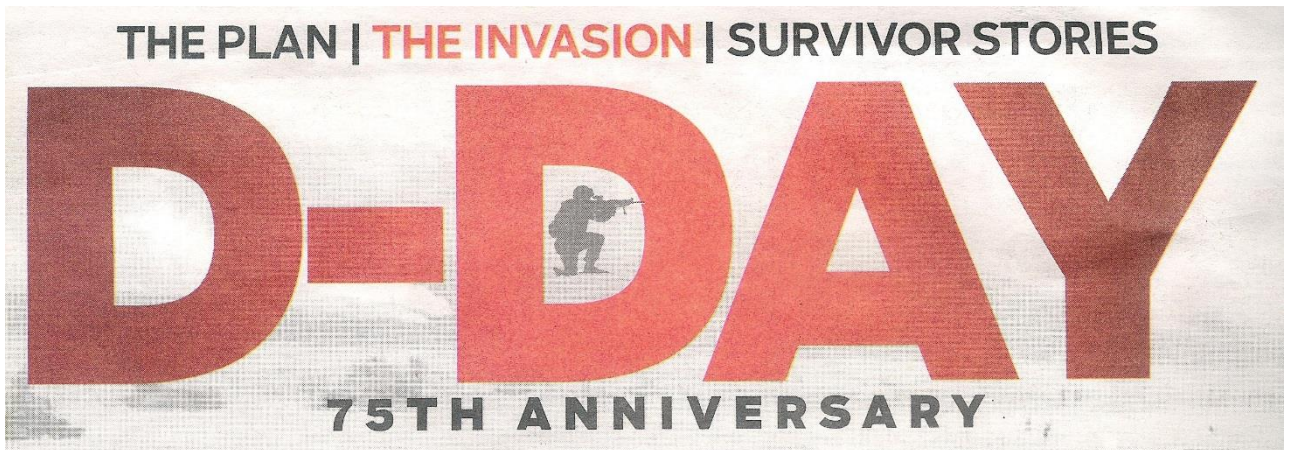

... From Free Time Hobbies sales@freetimehobbies.com

**Odds and Ends
Contributed by
Club Members &
Friends**

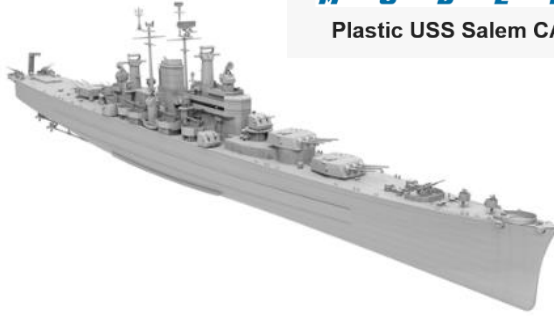

From: [s palmer \[mailto:sewingsquid@yahoo.com\]](mailto:s palmer [mailto:sewingsquid@yahoo.com])
Subject: D-Day beaches today

https://urldefense.proofpoint.com/v2/url?u=https-3A__www.yahoo.com_news_photos-2Dthe-2Dd-2Dday-2Dlanding-2Dbeaches-2D135627393.html&d=DwlCaQ&c=sJ6xIWYx-zLMB3EPkvcnVg&r=jzlfSSorEPNo37OXhPxyKgCet5y6tQ2EZ0WULQcGYH4&m=i6DvNn_ofU_H5iG6ant18_uc6n5sQejuOdaZDf4cqW8&s=Cy09fywIBwf7e3MPh87i3yck8BNfKLKqBs-f7nv9Cow&e



A former German defense bunker sits along a stretch of coastline that was known as 'Utah Beach' during the D-Day Beach landings on April 30, 2019 in Audouville-la-Hubert, on the Normandy coast, France.

.... From AUTOWORLD! .. Out of this world!



Answer to the previous page: The soldier in the "D" of D-Day is a modern U.S. soldier with an M-4 rifle, ⁴³

Coming events

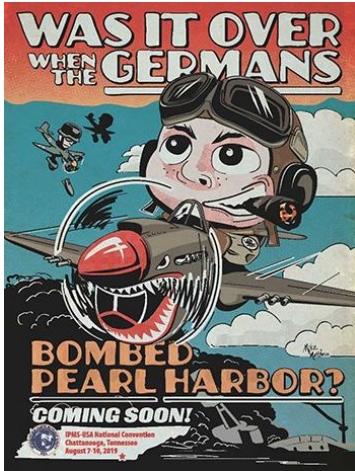

AUGUST 7-10, 2019 CHATTANOOGA, TENNESSEE

Was it over when the Germans bombed Pearl Harbor? Find out when you attend the 2019 International Plastic Modelers' Society USA Nationals in Chattanooga Tennessee. The **Chattanooga Scale Modelers**, along with a number of other regional clubs are putting together a nationals like no other.

For any questions, please email Mike Moore at mmoore1132@gmail.com.

As of 4-22-19 all four original Convention hotels have been sold out. Please bear with us as we try to secure additional rooms at discounted rates. Check back in a day or two and we'll have more information!

PAMSCON

About the Event...

Our annual one day show being held at the Plant City Strawberry Fairgrounds. it features vendors, a raffle, and contest.

Event Information

Event Date: June 15, 2019 (All day)

Location

Name: Plant City Strawberry festival
Address: 2301 W. Oak Ave, Plant City, FL, 33563

Region Number: [Region 11 - Florida](#)
Event Host: Polk Area Model Society

Hosting IPMS/USA Chapter(s): [IPMS/Polk Area Model Society](#)
Website: www.polkareamodelsociety.com

Contact Information

Contest Chairperson's Name: William Finley
Phone: 863-514-6188
E-mail: bowhuntenwill@aol.com

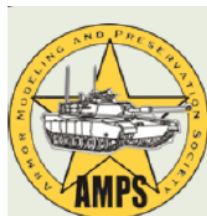

South Carolina Scale Model Mega Show

Saturday, June 22, 2019

National Guard Armory, 1225 Bluff Road, Columbia, SC

For all our AMPS South Region friends, we'd like to invite you to our next show hosted in conjunction with the IPMS/Mid-Carolina chapter. We'll be back in the same venue for the third year in a row. This year we'll have a few more vendor tables available (we sold out a couple months before the show last year), food trucks and, as in the past, free access to the SC National Guard Museum right next door. General admission is still free, and entrants only pay a single registration fee to enter models into both sides of the show (AMPS and IPMS).

Happy Modeling!

Mike Roof, Chapter Contact, AMPS Central SC "Wildcats"

Coming events

<https://modelpalooza.org/>

MODELPALOOZA

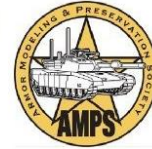

Modelpalooza/AMPS 2019 will be held at the **WorldGate Resort Hotel and Conference Center** (3011 Maingate Ln, Kissimmee, FL 34747; formerly Park Inn by Radisson Resort & Conference Center Orlando) on October 18th through the 20th. This is the same great show you have come to appreciate – all scale models of all types are welcome. New for 2019, all Military Vehicles will be judged using AMPS scoring rules. All remaining Entry Groups will be scored using the open judging rules specified on the Judging page.

Register for rooms at the resort (use Group Code Modelpalooza) \$74 per night Single/Double Rate with no Resort Fee added. Important: note that you may sometimes find what seems like a lower rate by using Expedia or another booking agent – however you will be required to pay the \$20 Resort Fee unless you book using the Modelpalooza code. You must also book your room before October 3rd to get the room block and use the code. Please call (407) 396-1400 to reserve a room or use this link.

Schedule of Events

Friday, Oct. 18th

9am – Advanced Aircraft Workshop (Oleander Room) pre-registration \$120 required
5pm – 7pm AMPS Judges Training Course (Oleander Room – outside main ballroom)
7pm – Venue Open for Registration (Royal Palms Ball Room)
9pm – Venue Closes

**Colonial
Photo & Hobby INC.**

Saturday, Oct. 19th

9am – Venue Open for Registration (Royal Palms Ball Room)
9am – Venue Open for Attendee Access
12pm – Modeler Registration Ends
1pm – Seminar: “Weathering Essentials: Chipping and Washes” – Johnny and Jay Grenot
3pm – Seminar: “Salt and Hairspray Weathering” – Vince Pedulla
5pm – Venue Closes
8pm – Hospitality Room – 7th Floor Presidential Suite

Sunday, Oct. 20th

9am – Venue Open (Main Ball Room)
10am – Seminar: “Modeling using 3D Printing” – Mike Roof
12pm – Awards Ceremony (Seminar area – Royal Palms Ball Room)
1pm – Show ends promptly after Ceremony
3pm – Venue Closes for All Access



Frank Ahern, – Secretary – ahernf@gmail.com
Home: (352) 375-3723; Cell: (352) 226-6785

If you have a modeling tip you would like to share with your fellow modelers, please send us a copy so we can put it in the newsletter. We need articles for the Newsletter and the Web Site!

If you just opened up that new kit and want to give a box or build review, write it up and we'll put it in the newsletter and put it on the Web Site. Just read a good book, tell us about it! Got a great tip, share it with your fellow club members. This is your Newsletter and your Web Site and they're only going to be as good as YOU make them so contribute something to the cause. Don't be afraid to ask for assistance if you have something you want to share, we'll be happy to assist you in making it happen!

Don't forget to support your local hobby shop.

Rob's Hobby World
Rob Stevely: Proprietor 8585 SW Hwy 200 unit 14
Ocala, FL 34474 www.robshobbyworld@MSN.com
Mon.-Fri.: 10 AM to 5:30PM; Sat.: 9AM to 4PM; Sun: Close

Please check out WWW.IPMSUSA.ORG for the latest information from IPMS National Headquarters and for information about joining IPMS.

Please use one of the links below or go to the IPMS Membership page for more information about joining IPMS USA.

http://www.ipmsusa3.org/uploads/ipms_application_form_2016.pdf
<http://www.shopipmsusa.org/product-p/adult-membership.htm>
<http://www.shopipmsusa.org/product-p/family-membership.htm>

Frank Ahern, – Secretary – Newsletter Editor ahernf@gmail.com
Home: (352) 375-3723; Cell: (352) 226-6785

UPCOMING EVENTS

This list contains modeling events with the **IPMS Region-11 Events listings** in bold.

June 15 Polk Area Model Society PAMScn, Plant City

Jun 21-22 IPMS/AMPS Mega Show, Columbia, South Carolina

July 20 North Florida AMPS meeting, Camp Blanding museum, 10 AM

Aug 7-10 IPMS Nationals, Chattanooga, Tennessee

Sept 21 North Florida AMPS meeting, Camp Blanding museum, 10 AM

Oct 18-20 IPMS/AMPS - Modelpalooza with AMPS armor judging, Orlando, FL

IPMS Membership



International Plastic Modelers' Society/USA Membership Application / Renewal Form

It is of great importance, both at the local level (IPMS Gators) and at national level. The Club officers strongly recommend joining IPMS as an individual which provides yearly six issues of the IPMS Journal (which is better than ever) and the opportunity to participate at the IPMS National Convention .

A copy of the membership application is on the right or available at the IPMS / USA website address, www.ipmsusa.org. Complete the form and return it to the address listed at the bottom of the form along with your method of payment.

New Renewal IPMS #:

Name: _____

Address: _____

City: _____ State: _____

Zip Code: _____

Phone: _____ E-Mail: _____

Chapter Affiliation, if any: _____

Junior (17 years or younger)	\$17.00	_____	Date of Birth: _____
Adult	One year	\$30.00	_____
	Two years	\$58.00	_____
	Three years	\$86.00	_____
Canada & Mexico		\$35.00	_____
Foreign	Surface	\$38.00	_____

Family (1 set of Journals) _____ ← Adult fee + \$5.00 # of cards? _____

Your Signature: _____

If recommended by an IPMS member, please provide his/her:
Name: _____ IPMS #: _____

PAYMENT OPTIONS:

Cash	<input type="checkbox"/>		Amount: _____
Check	<input type="checkbox"/>	Check #: _____	Amount: _____

Billing Address, if different than above -

Address: _____

City: _____ State: _____

Zip Code: _____

Applications should be printed and mailed to: IPMS/USA, PO Box 56023, St. Petersburg, FL 33732-6023.

For folks renewing on-line: <http://www.shopipmsusa.org/category-s/100.htm>

GATOR MODELERS



How to get to the meeting

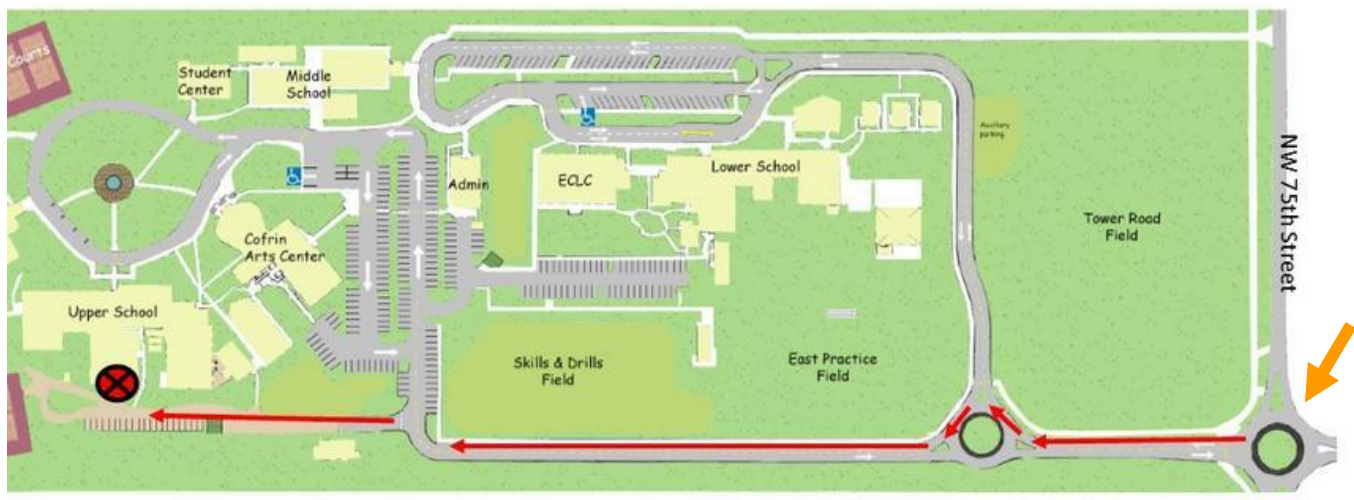
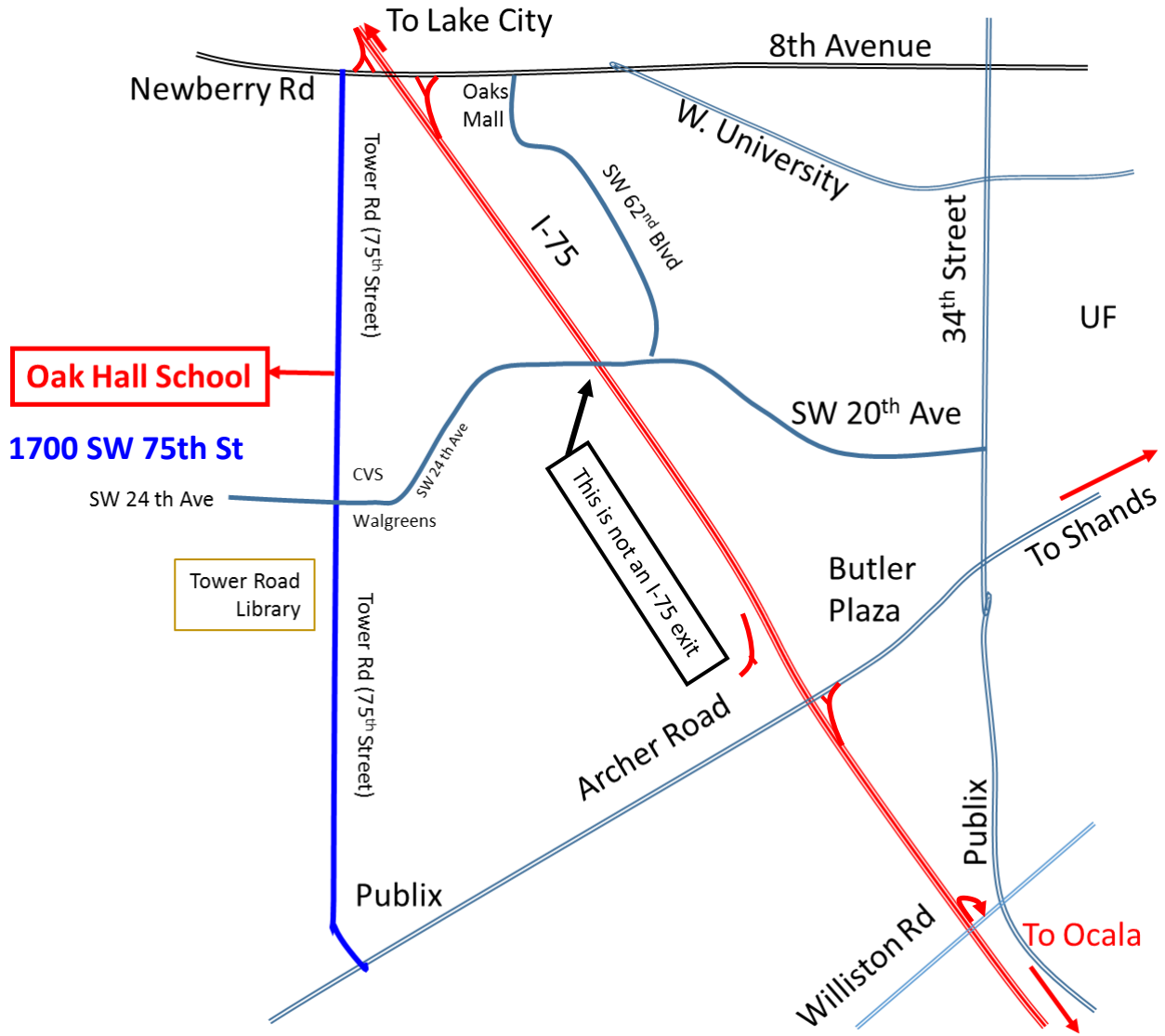

Note: There is a new entrance to Oak Hall School south of the previous entrance that we used. This entrance is off of a roundel on NW 75th Street (a.k.a. – Tower Road).



www.gatormodelers.org

Wild Paint

By Jack Mugan



**JULY MEETING:
TUESDAY, JULY 16, 2019!**